

# Instructions for Safe Use



(Certification N:o VTT 15 ATEX 003)

Thank you for choosing SLAM® Splitter –portable unit for your job site. Purpose of this manual is to provide you all the necessary safety and product information to conduct your job conveniently and without any risks for health and safety.



**WE DON'T TAKE SAFETY LIGHTLY.  
WE PROVIDE LIGHT SAFELY.**

Atexor Oy Seinäjoki • P.O.Box 89 • FIN-60101 Seinäjoki • FINLAND  
www.atexor.com • Tel: +358 20 734 3250 • Trade Reg. No. 486.515 • VAT No. FI08370823

## Contents

Instructions for Safe Use.....	1
1. Introduction to SLAM® Splitter.....	3
1.1 Technical data.....	3
1.2 Certification of equipment.....	4
1.3 Standard unit construction.....	5
1.4 Quality Guaranteed.....	6
1.4.1 General.....	6
1.4.2 Individual testing reports.....	6
2. Prior to use.....	7
2.1 Selection of right equipment.....	7
2.1.1 Intended purpose of equipment.....	7
2.1.2 Application of use (Zone XX) in accordance with equipment category.....	8
2.1.3 Gas explosion group (IIA, IIB or IIC) in accordance with Equipment group (IIA, IIB or IIC).....	8
2.1.4 Temperature class of the equipment.....	8
2.1.5 Environmental criteria.....	9
3. Operating instructions.....	10
3.1 Personnel.....	10
3.2 Visual inspection of SLAM® Splitter.....	10
3.4 Special attention on 3-pole use (24 V or 42 V).....	10
3.5 Connection to the supply.....	10
3.5.1 Requirements for supply (electricity).....	11
3.5.2 Connecting relating equipment to the SLAM® Splitter.....	11
4. Inspection & Maintenance.....	12
4.1 After Use.....	12
4.2 Maintenance.....	12
4.3 Testing.....	12
4.4 Repair report.....	13
Helpdesk.....	15

# 1. Introduction to SLAM® Splitter

(Certification N:o VTT 15 ATEX 003)

This instruction manual guides you through the process of selecting and adopting SLAM® Splitter unit for your work site. The manual regards the following SLAM® Splitter -types:

## 1.1 Technical data

SLAM® Splitter EX 2P +E version

SLAM® Splitter EX 3P version (SELV)

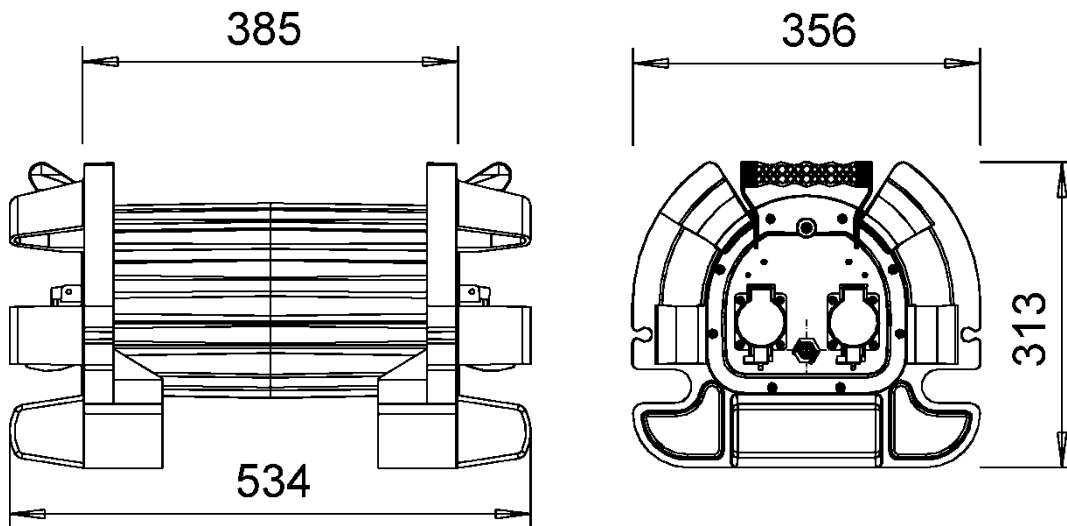

## 1.2 Certification of equipment

The SLAM® Splitter-series has been designed, tested and certified (according to ATEX) for portable use. There is no “X” –mark in the certificate for special conditions of safe use of the equipment. The equipment is to used properly and according to its ratings, documentation and local applicable laws. Local, national certificates of these units may exist outside the region of EU. Possible variations is marked on the typelabel of the product (e.g IP XX)

The aforementioned SLAM® Splitter-types are certified e.g as follows. You may find brief explanation of certificate beneath:

**CE<sub>0537</sub>**  **II 2 GD**      **Ex e d IIC T4 Gb**  
**Ex tb IIIC T80 °C Db**  
**T<sub>amb</sub>: -20°C...+55°C**  
**or**  
**Ex e d IIC T4 Gb**  
**Ex tb IIIC T80 °C Db**  
**T<sub>amb</sub>: -20°C...+40°C**

**CE<sub>0537</sub>** = Valid production quality system approved and notified by VTT (Finnish Notified Body, listed by EC)

 = Certified for explosion-hazardous areas  
**II** = Certified for use in areas excluding mines  
**2** = Equipment category (suitable for Zone 1&21 and Zone 2&22)  
**G** = Certification taking account explosion hazardous GASES  
**D** = Certification taking account explosion hazardous DUSTS

### Explanation of marking for explosion hazardous area due to Gases (Ex e mb IIC T4 Gb):

**Ex** = Certified for use in explosion hazardous areas  
**e** = Explosion protection method increased safety (of certain components)  
**d** = Explosion protection method flameproof  
**IIC** = Equipment group (for all IIA, IIB and IIC gases)  
**T4** = Maximum inside temperature of the unit is 135 °C (within the ambient temperature range specified on the type label of the product)  
**Gb** = Explosion Protection Level (EPL) marking for “HIGH” level of protection. Equipment for explosive **GAS** atmospheres, which is not a source of ignition in normal operation or during expected malfunctions

# 5/16

## Explanation of marking for explosion hazardous area due to Dusts (Ex t IIIC T70 °C Db):

**Ex** = Certified for use in explosion hazardous areas

**tb** = Explosion protection method “protection by enclosure”

**IIIC** = Equipment group for conductive dusts (including IIIA, IIIB and IIIC dusts)

**T80°C** = Maximum OUTSIDE surface temperature of the unit is 80 °C (within the ambient temperature range specified on the type label of the product )

**Db** = Explosion Protection Level (EPL) marking for “HIGH” level of protection. Equipment for explosive **DUST** atmospheres, which is not a source of ignition in normal operation or during expected malfunctions

### 1.3 Standard unit construction

The following list familiarizes you with some common unit features important to recognize:

**Portable:** The equipment is designed and tested to be moved when energized (in this case without danger of ignition source capable of starting an explosion (e.g static electricity)

**2P+E:** Electrical system having Phase (P), Neutral (N) and Protective Earth (PE). With Extra-Low-Voltage system is recognized as PELV (Protective Extra Low Voltage)

**3P :** Electrical system having Phase (P), Neutral (N) and conductor for bonding (yellow/green). With Extra-Low-Voltage this system is recognized as SELV (Safety Extra Low Voltage).

**Cable:** Standard cable of the SLAM® Splitter–series is H07BQ-F. This cable has polyurethane (PUR) outer sleeve. PUR withstands well chemicals as well mechanical wearing. However, the user has an option to specify cable type in accordance with work site requirements of own.

### Other common accessories (optional):

To view options on accessories, please visit <http://www.atexor.com> for further study or call +358 20 734 3250.

## 1.4 Quality Guaranteed

### 1.4.1 General

The SLAM® Splitter-series is designed, certified, manufactured and tested under ISO 9001:2008 quality system as well as additional requirements of the Directive 94/9/EC (ATEX). The SLAM® Splitter-series is designed and tested according to the latest directives and standards. The referred directives and standards of the production date in case are stated on the Declaration of Conformity which is included in the delivery.

### 1.4.2 Individual testing reports

Each SLAM®-unit has its own individual serial number and is provided with an original, individual testing report when leaving the factory. The year of manufacture is specified on the type label of the equipment. Following tests have been done for SLAM® Splitter-units according to standards relating to portable Splitter for explosion hazardous area. The Declaration of Conformity is specifying the relevant standards. The testing report included in the delivery specifies the results of the factory tests for that particular unit. The testing report typically specifies the following tests:

#### **PE –resistance test**

The main purpose of this test is to measure persistence of earth conductor. Vital test for electrical safety as well as explosion safety because of e.g static electricity control.

Each of the sockets is tested including Live, Neutral and Earth conductor. The test current is 10 A (current) and the overall resistance should not exceed 0,5 ohm.

#### **High voltage test (electrical strength)**

The purpose of this test is to measure leakage current through insulation. Vital test for revealing broken components or similar failures which can not be identified visually. Testing voltage applied is 2130VDC. Maximum leakage current is 5mA.

#### **Test of expected use of equipment**

The Splitter is subjected to shaking and vibration – to see that all the internal wires are properly attached and components are not loose.

#### **Operational test of Splitter and accessories**

The unit is plugged-in and checked that it is working properly after all accomplished tests above.

## Visual inspection

A final check to see everything is fine (screws attached properly, wires connected and required markings attached).

## 2. Prior to use

### 2.1 Selection of right equipment

You need to be sure that the equipment you intend to take into explosion hazardous area matches up with the zone classification and other safety requirements related. At least the following points should be notified prior to use:

#### 2.1.1 Intended purpose of equipment

Please keep in mind what the actual application of equipment is. For example in case the equipment is to be moved when connected to the supply it needs to be designed for that purpose. If the certification is mentioning “portable” it means that the equipment is suitable and tested for portable use. If the certification does not mention portable it means that the equipment shall not be moved when it is in operation (reliable fixing of equipment).

**SLAM® -units are designed and tested for portable use.**

## **2.1.2 Application of use (Zone XX) in accordance with equipment category**

Operator has the best knowledge of area classification at his site. To help the operators' selection of equipment the certification is describing the equipment category. For explosion hazardous areas there are three equipment categories

Category 1 product is suitable for use in Zones 0, 1 and 2 / (20, 21 and 22)

Category 2 product is suitable for use in Zones 1 and 2 / (21 and 22)

Category 3 product is suitable for use in Zones 2 / (22)

**SLAM® -units mentioned in this instruction fall into Category 2 equipment.**

## **2.1.3 Gas explosion group (IIA, IIB or IIC) in accordance with Equipment group (IIA, IIB or IIC)**

This information is vital because the substances require different amount of energy to be ignited. Safety requirements for equipment are not the same for different substances (e.g. static electricity requirements). Therefore making the selection easier the gases are divided to three different groups (IIA, IIB and IIC). Further information about the substances can be found from EN 60079-20 (Data for flammable gases and vapours, relating to the use of electrical apparatus).

**SLAM® -units mentioned in this instruction are Equipment group IIC.**

## **2.1.4 Temperature class of the equipment**

Please observe the Ignition Temperature (IT) of the substance creating the explosion hazard at your site. Select the equipment based on IT of the substance. The temperature of the equipment must be lower than IT. The highest temperature of the equipment is specified by using Temperature Classes T1 to T6.

Example:

Petroleum IT is approximately 250 Celsius → Maximum allowed temperature class of the equipment is T3 (< 200° C)

**SLAM® -units mentioned in this instruction are Temperature Class T4 (GASES)**  
**SLAM® -units mentioned in this instruction maximum surface temperature of 70°C (DUSTS)**



## 2.1.5 Environmental criteria

Please observe the ambient temperature of the application in use because certification is valid for temperatures specified on the type label of the product. Please see type label of the product for further data. If the equipment is used in other temperatures than mentioned the safety can not be guaranteed.

**Selection and use of equipment is always under the responsibility of the operator. Please note that all of the aforementioned criteria are to be passed when selecting the equipment.**

**Please do not take any unnecessary risks.**



## 3. Operating instructions

### 3.1 Personnel

The use of the equipment is to be controlled and accepted by the operator. The personnel using the unit have to be authorized by the operator or his representative. In case of further training of using the equipment please contact the local supplier of this equipment.

### 3.2 Visual inspection of SLAM® Splitter

As for all equipment to be used inside explosion hazardous area it is recommended that before taking the unit into Ex –area, a visual re-inspection on the unit was taken and an analysis made the unit to be un-damaged and fully operational.

In case faults or defects on the unit are noticed, it is prohibited to take such a unit into Ex – area until corrective actions have been made.

### 3.4 Special attention on 3-pole use (24 V or 42 V)

Using SLAM® Splitter -unit with 3-pole socket outlets (with bonding) is a simple way to solve the problems with static electricity of relating equipment. By connecting the bonding cable (supplied with Splitter) to the local equipotential system at the site the secondary side sockets do have correct potential. Relating equipment can have a three core cable (P, N, Bonding) making it more simple and practical to do the connection of metal parts of relating equipment (also external metal parts). No extra bonding arrangement required.

### 3.5 Connection to the supply

It is recommended that the unit is first connected to the mains before entering the explosion-hazardous area.

## 3.5.1 Requirements for supply (electricity)

The following main requirements should be taken into account:

**Supply voltage:** Variation may be maximum +/- 6% from the value stated in the unit type label.

**Type of Supply:** Class 1 (incorporating protective earth conductor) or Class 3 (ELV incorporating protective earth conductor or bonding arrangement)

**Current:** Maximum current of the system is 16 A

**Frequency:** Standard 50 Hz if not otherwise stated in the type label.

**Fuse protection:** The supply has a fuse with a breaking capacity of at least 1500 A

Please observe the type label for further data.

## 3.5.2 Connecting relating equipment to the SLAM® Splitter

SLAM® Splitter -units are equipped with Ex –certified sockets in the factory. The type and number of the sockets are considered as an option so they are added to the unit upon customer's special request.

Please note the following operational characteristics:

- In case the ambient temperature is between -20°C -- +55°C and the nominal output voltage is 12 VAC, 24 VAC, 42 VAC, 110 VAC or 230 VAC then the maximum output current is 16 A. The type of socket is A.T.X.
- In case the ambient temperature is between -20°C -- +40°C and the nominal output voltage is 110 VAC or 230 VAC then the maximum output current is 16 A. The type of socket is CEAG.

When connecting relating equipment to the SLAM® Splitter please observe the operational characteristics of the equipment in case and ensure that above mentioned special conditions are taken account.

## 4. Inspection & Maintenance

### 4.1 After Use

Take the following steps after the SLAM® Splitter –unit has been taken out from Ex –area:

1. Clean the unit with a damp cloth (do not use detergents or solvents)
2. Have a visual check on the unit (condition of cable, enclosure, tightness of parts)
3. Let the unit dry in open air

### 4.2 Maintenance

The following procedure should be taken in case the SLAM® Splitter -unit needs to be repaired:

1. Maintenance may be carried out only outside Ex –area
2. Person responsible for maintenance should have been trained the basics of explosion-protection as well electricity
3. Only original spare parts from the manufacturer should be used. Please note that there are no components in this unit which can be repaired by using glue, silicone or any other similar method.
4. Maintenance instructions with exploded-view diagram and spare parts list are available at your local distributor and the manufacturer. Please, when requesting maintenance instructions with exploded-view diagrams, include the model and serial number of the product.

### 4.3 Testing

Tests are to be done according to EN 60079-19 until returning the repaired unit back to operation. Below mentioned tests shall be done in addition to the tests specified in EN 60079-19:

- PE –resistance test
- High-voltage test (500 VDC between Phase& Neutral against P/E conductor)
- Operational test (e.g. wiring of sockets)

- Test of expected use (vibrations, shaking)

Proper testing ensures safe operation of repaired equipment.

## 4.4 Repair report

The operator is responsible for keeping up to date record of the condition of his equipment (EN 60079-14). Ensuring the availability of this important information each repair procedure should be written down in repair report according to EN 60079-19.

This report should reveal at least:

- Person who conducted the maintenance
- Date of maintenance
- Procedure of maintenance
- Signature of person responsible accepting the maintenance

More information about the use of Electrical Apparatus for Explosive Gas Atmospheres is available at:

EN 60079-14 (Electrical installations in hazardous areas)

EN 60079-10 (Classification of hazardous areas)

EN 60079-17 (Inspection and maintenance of electrical installations in hazardous areas)

IEC 60079-19 (Repair and overhaul for apparatus used in potentially explosive atmospheres)





**16/16**

**Helpdesk**

Under any doubt or question, please contact your local distributor or the manufacturer.

Contact details:



P.O.B 89, FIN-60101 SEINÄJOKI, FINLAND

Phone: +358 20 734 3250

Fax: +358 20 734 3299

Email: [info@atexor.com](mailto:info@atexor.com)

Web: <http://www.atexor.com>

